



Zhongshan Xingke automation equipment Co., Ltd

Tel : 0760-8521 3727

Web: [www.zsxingke.com/cn](http://www.zsxingke.com/cn)

Add : No.11, Qimin South Road, Torch Development Zone, Zhongshan City, Guangdong Province, China



Wonderful, waiting for you to find out



Zhongshan Xingke Automation Equipment Co., Ltd.

# PRODUCT MANUAL



SAVE TIME EFFORT AND EFFORT

## ► COMPANY INTRODUCTION

### Zhongshan Xingke Automation Equipment Co., Ltd.

Zhongshan Xingke Automation stands in the Torch Development Zone, a national high-tech industrial zone, located in the southwestern part of the Pearl River Delta, adjacent to Foshan, Zhuhai, Dongguan, Shenzhen, and Guangzhou. The Guangzhou-Zhuhai-Macao Expressway and the light rail transit traverse the whole city and the transportation is convenient.

The company is an automation equipment company with independent research and development, design, program development, production, and sales. It has obtained a number of patent technology and software copyright, and get the title of national high-tech enterprise. The production projects involve automatic packaging, dispensing, assembly, screwing, and other industrial machinery and its application engineering, serving many industries such as hardware, electronics, electrical appliances, plastics, medical, lighting, bathroom, furniture, engineering, etc. The company takes honesty and service first as its service concept; meticulous and pursuit of excellence as its work attitude; accurate research and development plans, excellent product quality. And perfect before sales and after-sales services as the company's corporate purpose. The goal of the company is to provide users with reliable automation solution, in order to saves time, effort and worry.

The company specialize in automatic packaging machine, automatic packaging production line, automatic screw machine, automatic dispensing machine, vibrator bowl, non-standard automation equipment, etc.

Mainly targeted industries are: hardware screws, furniture industry, lighting accessories, electrical accessories, toys, sanitary ware, plastic products, etc.

Xingke welcomes friends from all over the world and looks forward to cooperating with you.

# CONTENTS

<b>01</b>	<b>B860</b>
<b>05</b>	<b>B860T</b>
<b>09</b>	<b>B860Z</b>
<b>15</b>	<b>C802</b>
<b>17</b>	<b>Non-standing Packaging</b>
<b>21</b>	<b>Cylinder Film</b>
<b>23</b>	<b>Packaging Auxiliary Equipment</b>
<b>25</b>	<b>Pillow Packaging Machine</b>
<b>27</b>	<b>Sealing and Cutting</b>
<b>30</b>	<b>Platform Machine</b>
<b>34</b>	<b>Accessories</b>



Team, quality, perfection /SERVICE

Excellent team, from analysis-discussion-qualitative-design drawing-data verification-fine construction-machinery factory-after-sales training. Do the best in this whole process and get the trust of customers.



Do the best /SERVICE

Make the best quality products, create a first-class brand. Offer the best service to each customer and to produce excellent quality product to meet your expectation. Focus on the product and service.



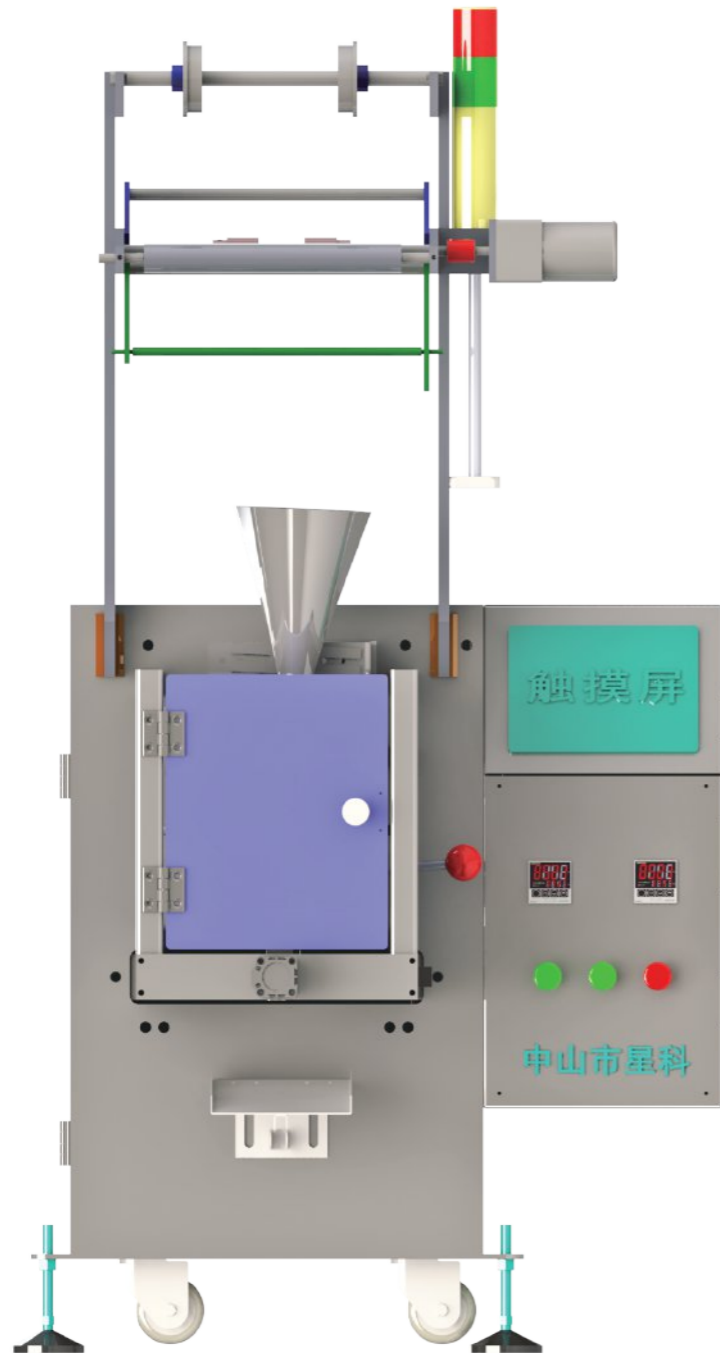

**XK-B860**

**XK-B860S**

1. This product is applicable to the product shape is long and irregular, large aspect ratio, product, or on the surface requirement high after electroplating, spray paint, paint and other products, such as, after plating processing plastic products, toys, bolt, screw driver, cable, etc., using artificial delivery material, belt transmission material to molding machine, automatic filling packaging.  
2. It is suitable for "OPP/PP/ lamination film" as sealing material.

★ Performance parameter

Equipment model: XK-B860  
Product name: Hand Throw Packaging Machine  
Counting method: manual placement  
Bag size: width 40-140 length less than 200 (conventional 140)  
Packing speed: 1-60 bags/min  
Sealing shape: stripe, back seal/three side seal (usually back seal)  
Voltage power: 220V/50HZ P≈0.6KW  
Air supply: 0.4-0.8MPA  
Bag mouth shape: figure cutter tooth shape  
Dimensions: length 1100mm/ width 750mm/ height 1550mm  
Weight: about 100KG

★ Performance parameter

Equipment model: XK-B860S  
Product name: Hand Throw Type Small Packaging Machine  
Counting method: manual placement  
Bag size: width 40-140 length less than 200 (conventional 140)  
Packing speed: 1-60 bags/min  
Sealing shape: stripe, back seal/three side seal (usually back seal)  
Voltage power: 220V/50HZ P≈0.6KW  
Air supply: 0.4-0.8MPA  
Bag mouth shape: figure cutter tooth shape  
Dimensions: length 1700mm/ width 750mm/ height 1550mm  
Weight: about 100KG

★ Technical characteristics

1. Automatic filling, automatic packing, sealing function, output count.
2. Adopt intelligent temperature control system, stable temperature control, temperature can be adjusted according to needs.
3. The length of the bag can be adjusted, the total amount of the package can be adjusted, and the automatic alarm can be reached when the set number of times is reached.
4. After packing, the bag is uniform and firm. It can also be equipped with coding machine, check weighing, labeling machine, hoist and other expansion equipment.

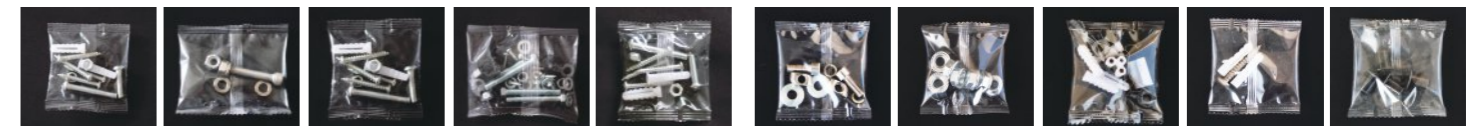



### XK-B860X

1. Vibrator bowl automatic arrangement of materials, automatic counting, automatic filling, automatic packing, sealing function, output count.
2. Adopt intelligent temperature control system, stable temperature control, temperature can be adjusted according to needs.
3. The length of packaging bag is adjustable, the total number of packaging is adjustable, the set number of automatic alarm.
4. After packing, the bag is uniform, neat, beautiful and firm. It can also be equipped with coding machine, check weighing, labeling machine, hoist and other expansion equipment.

#### ★ Performance parameter

Equipment model: XK-B86X  
 Product name: Hand Throw Big Bag Type Packaging Machine  
 Counting mode: manual placement  
 Bag size: width 40-200 length less than 300 (conventional 140)  
 Packing speed: 1-60 bags/min  
 Sealing shape: stripe, back seal/three side seal (usually back seal)  
 Voltage power: 220V/50HZ P≈0.6KW  
 Air supply: 0.4-0.8MPA  
 Bag mouth shape: figure cutter tooth shape  
 Dimensions: length 900mm/width 900mm/height 1800mm  
 Weight: about 150KG

#### ★ Scope of application and functional features

1. This product is suitable for products with long, irregular product shapes, large length and width ratios, or products that have extremely high surface requirements such as electroplating, spray painting, baking varnish and other process treatments, electroplating process plastic products, toys, bolts, screwdrivers, Data line, etc., using manual material input, belt conveying material to the forming, automatic filling and packaging.
2. It is suitable for "OPP/ CPP/ lamination film" as sealing material.



### XK-B861

#### ★ Performance parameter

Equipment model: XK-B861  
 Product name: Single Vibrator Bowl Packaging Machine  
 Counting mode: optical fiber counting/blocking and putting  
 Bag size: width 40-140 length less than 200 (conventional 140)  
 Packing speed: 1-60 bags/min  
 Sealing shape: stripe, back seal/three side seal (usually back seal)  
 Voltage power: 220V/50HZ P≈0.6KW  
 Air supply: 0.4-0.8MPA  
 Bag mouth shape: figure cutter tooth shape  
 Dimensions: length 1100mm/ width 750mm/height 1550mm  
 Weight: about 150KG

#### ★ Scope of application and functional features

1. This product is suitable for automatic packaging of single materials, such as screws, nuts, flat pads, spring pads, toys, standard parts, etc. After automatic counting of the vibrator bowl, the product will be filled into the molding machine for automatic packaging, and can also use the spare space of the equipment to manually put other materials mixed packaging.
2. It is suitable for "OPP/ CPP/ lamination film" as sealing material.



### XK-B862

#### ★ Performance parameter

Equipment model: XK-B862  
 Product name: 2 Vibrator Bowls Chain Bucket Packaging Machine  
 Counting method: optical fiber counting/blocking and putting  
 Bag size: width 40-140 length less than 200 (conventional 140)  
 Packing speed: 1-60 bags/min  
 Sealing shape: stripe, back seal/three side seal (usually back seal)  
 Voltage power: 220V/50HZ P≈ 0.6KW  
 Air supply: 0.4-0.8MPA  
 Bag mouth shape: figure cutter tooth shape  
 Dimensions: length 1100mm/ width 1000mm/ height 1550mm  
 Weight: about 180KG

#### ★ Scope of application and functional

1. This product is applicable to automatic mixing under 2 kinds of materials or separate packaging, such as screws, nuts, plain washers, spring washers, toys, standard parts, etc., this product uses chain bucket turns box, vibrator bowl, automatic counting on materials to box, the bucket will to molding machine automatic packaging materials for the products, also can use artificial into other materials mixed packing equipment free space.
2. It is suitable for "OPP/ CPP/ lamination film " as sealing material.



### XK-B865

#### ★ Performance parameter

Equipment model: XK-B865  
 Product name: 5 Vibrator Bowls Packaging Machine  
 Counting mode: optical fiber counting/blocking and putting  
 Bag size: width 40-140 length less than 200 (conventional 140)  
 Packing speed: 1-60 bags/min  
 Sealing shape: stripe, back seal/three side seal (usually back seal)  
 Voltage power: 220V/50HZ P≈2KW  
 Air supply: 0.4-0.8MPA  
 Bag mouth shape: figure cutter tooth shape  
 Dimensions: length 1350mm/ width 1500mm/ height 1550mm  
 Weight: about 350KG

#### ★ Scope of application and functional features

1. This product is suitable for automatic mixing or separate packaging of 5 kinds of materials, such as screws, nuts, plain washers, spring washers, toys, standard parts, etc. After automatic counting of the vibrator bowl, the product will be filled into the box for automatic packaging, or other materials can be put into the mixed packaging manually by using the spare space of the equipment.
2. It is suitable for "OPP/ CPP/ lamination film" as sealing material.



# B860T

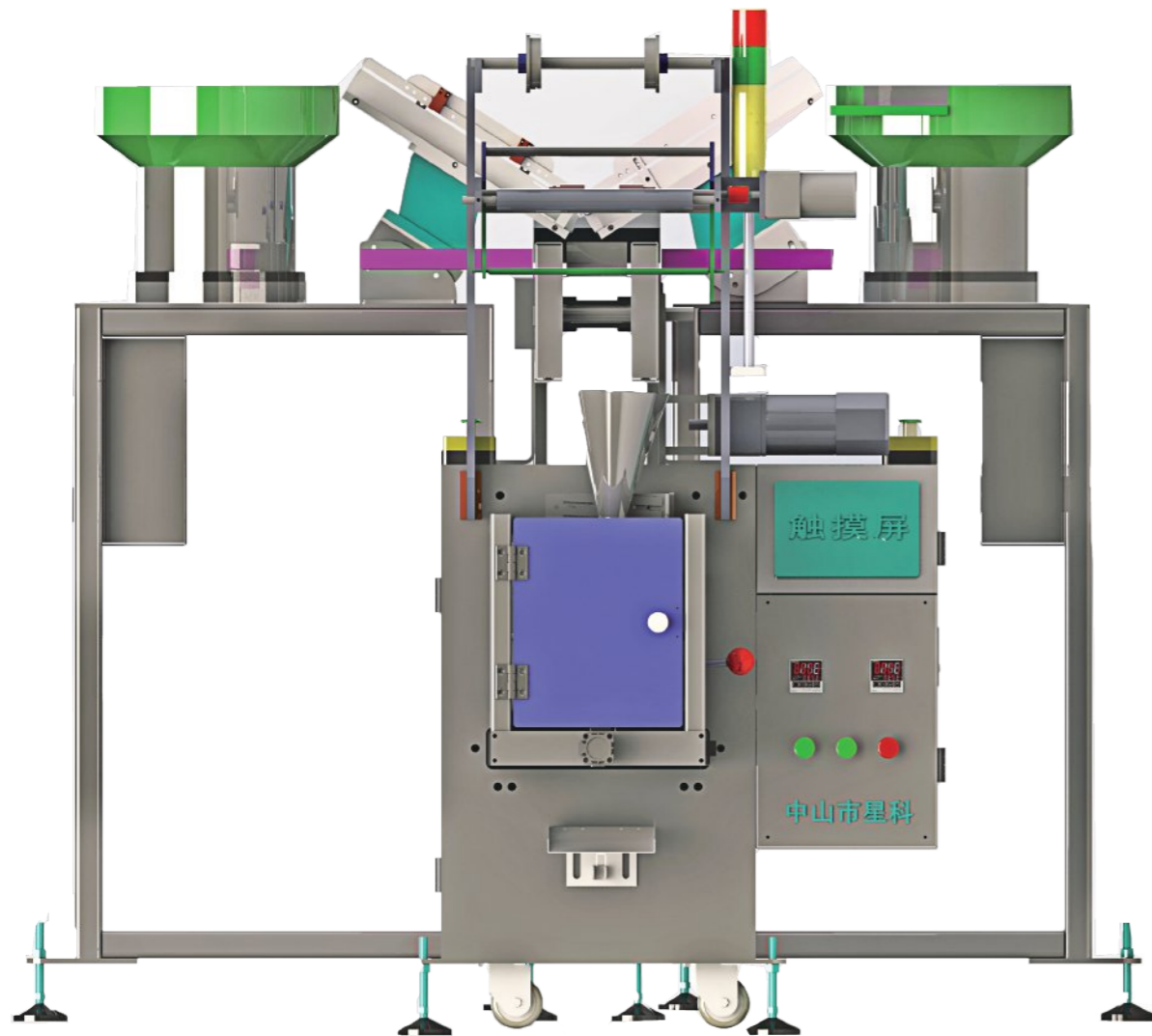

## ★ Technical characteristics

1. Automatic filling, automatic packing, sealing function, output count.
2. Adopt intelligent temperature control system, stable temperature control, temperature can be adjusted according to needs.
3. The length of the bag can be adjusted, the total amount of the package can be adjusted, and the automatic alarm can be reached when the set number of times is reached.
4. After packing, the bag is uniform, neat, beautiful and firm. It can also be equipped with coding machine, check weighing, labeling machine, hoist and other expansion equipment.



## ★ Performance parameter

Equipment model: XK-B860P  
 Product name: Hand Throw Belt Type Packaging Machine  
 Counting method: manual placement  
 Bag size: width 40-140 length 200 (conventional 140)  
 Packing speed: 1-60 bags/min  
 Sealing shape: stripe, back seal/three side seal (usually back seal)  
 Voltage power: 220V/50HZ P≈0.6KW  
 Air supply: 0.4-0.8MPA  
 Bag mouth shape: figure cutter tooth shape  
 Dimensions: length 1700mm/ width 750mm/ height 1550mm  
 Weight: about 100KG

## ★ Scope of application and functional features

1. This product is suitable for products with long, irregular product shapes, large length and width ratios, or products that have extremely high surface requirements such as electroplating, spray painting, baking varnish and other process treatments, electroplating process plastic products, toys, bolts, screwdrivers, Data, etc., using manual material input, belt conveying material to the forming machine, automatic filling and packaging.
2. It is suitable for "OPP/PPP/ lamination film" as sealing material.

## XK-B860P

## XK-B860T

## ★ Performance parameter

Equipment model: XK-B860T  
 Product name: Hand Throw Chain Bucket Packaging Machine  
 Counting method: manual placement  
 Bag size: width 40-140 length 200 (conventional 140)  
 Packing speed: 1-60 bags/min  
 Sealing shape: stripe, back seal/three side seal (usually back seal)  
 Voltage power: 220V/50HZ P≈0.6KW  
 Air supply: 0.4-0.8MPA  
 Bag mouth shape: figure cutter tooth shape  
 Dimensions: length 1700mm/ width 750mm/ height 1550mm  
 Weight: about 100KG

## ★ Scope of application and functional features

1. This product is suitable for placing and packaging various products, such as screws, nuts, flat washers, spring washers, toys, standard parts, etc. This product uses chain bucket type to drive the material box to rotate, manually put the material into the material box, chain bucket will fill the product to the molding machine for automatic packaging.
2. It is suitable for "OPP/PPP/ lamination film" as sealing material.



## ★ Performance parameter

Equipment model: XK-B862T  
 Product name: 2 Vibrator Bowls Chain Bucket Packaging Machine  
 Counting method: fiber counting/blocking and putting  
 Bag size: width 40-140 length 200 (conventional 140)  
 Packing speed: 1-60 bags/min  
 Sealing shape: stripe, back seal/three side seal(usually back seal)  
 Voltage power: 220V/50HZ P≈0.6KW  
 Air supply: 0.4-0.8MPA  
 Bag mouth shape: figure cutter tooth shape  
 Dimensions: length 2350mm/ width 1000mm/ height 1550mm  
 Weight: about 250KG

## ★ Scope of application and functional features

1. This product is suitable for products with long, irregular product shapes, large length and width ratios, or products that have extremely high surface requirements such as electroplating, spray painting, baking varnish and other process treatments, electroplating process plastic products, toys, bolts, screwdrivers, Data line, etc., using manual material input, belt conveying material to the forming, automatic filling and packaging.
2. It is suitable for "OPP/PPP/ lamination film" as sealing material.

## XK-B862T



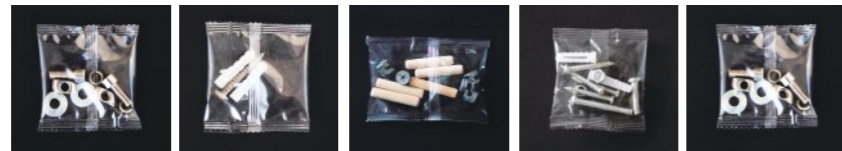

**XK-B864T**

1. Vibrator bowl automatic arrangement of materials, automatic counting, automatic filling, automatic packing, sealing function, output count.
2. Adopt intelligent temperature control system, stable temperature control, temperature can be adjusted according to needs.
3. The length of packaging bag is adjustable, the total number of packaging is adjustable, automatic alarm when the set number is reached.
4. After packing, the bag is uniform, neat, beautiful and firm. It can also be equipped with coding machine, check weighing, labeling machine, hoist and other expansion equipment.

★ Performance parameter

Equipment model: XK-B864T  
 Product name: 4 Vibrator Bowls Chain Bucket Packaging Machine  
 Counting method: optical fiber counting/blocking and putting  
 Bag size: width 40-140 length less than 200 (conventional 140)  
 Packing speed: 1-60 bags/min  
 Sealing shape: stripe, back seal/three side seal (usually back seal)  
 Voltage power: 220V/50HZ P≈1.5KW  
 Air supply: 0.4-0.8MPA  
 Bag mouth shape: figure cutter tooth shape  
 Dimensions: length 2350mm/ width 1500mm/ height 1550mm  
 Weight: about 350KG

★ Scope of application and functional features

1. This product is suitable for automatic mixing under 4 kinds of materials or separate packaging, such as screws, nuts, plain washers, spring washers, toys, standard parts, etc. After automatic counting of the vibrator bowl, the product will be filled into the box for automatic packaging, or other materials can be put into the mixed packaging manually by using the spare space of the equipment.
2. It is suitable for "OPP/PP/ lamination film" as sealing material.



**XK-B866T**

★ Performance parameter

Equipment model: XK-B866T  
 Product name: 6 Vibrator Bowls Chain Bucket Packaging Machine  
 Counting method: optical fiber counting/blocking and putting  
 Bag size: width 40-140 , length less than 200 (conventional 140)  
 Packing speed: 1-60 bags/min  
 Sealing shape: stripe, back seal/three side seal (usually back seal)  
 Voltage power: 220V/50HZ P≈ 2.2KW  
 Air supply : 0.4-0.8MPA  
 Bag mouth shape: figure cutter tooth shape  
 Dimensions: length 2850mm/ width 1500mm/ height 1550mm  
 Weight: about 400KG

★ Scope of application and functional features

1. This product is suitable for automatic mixing under 6 kinds of materials or separate packaging, such as screws, nuts, plain washers, spring washers, toys, standard parts, etc.. This product use chain bucket turns box, vibrator bowl, automatic counting on materials to box, the bucket will to forming machine automatic packaging materials for the products, also can use artificial into other materials mixed packing equipment free space.
2. It is suitable for "OPP/PP/lamination film" as sealing material.



**XK-B868T**

★ Performance parameter

Equipment model: XK-B868T  
 Product name: 8 Vibrator Bowls Chain Bucket Packaging Machine  
 Counting method: optical fiber counting/blocking and putting  
 Bag size: width 40-140 length less than 200 (conventional 140)  
 Packing speed: 1-60 bags/min  
 Sealing shape: stripe, back seal/three side seal (usually back seal)  
 Voltage power: 220V/50HZ P≈ 2.7KW  
 Air supply: 0.4-0.8MPA  
 Bag mouth shape: figure cutter tooth shape  
 Dimensions: length 3350mm/ width 1500mm/ height 1550mm  
 Weight: about 450KG

★ Scope of application and functional features

1. This product is suitable for 8 kinds of materials or separate packaging, such as screws, nuts, flat washers, spring washers, toys, standard parts, etc., this product adopts chain bucket type to drive the material box to rotate, and the vibrator bowl automatically counts the material into the material box. The chain bucket fills the product into the box, for automatic packaging, and can also use the equipment space to manually put other materials into mixed packaging.
2. It is suitable for "OPP/PP/ lamination film" as sealing material.



**XK-B870T**

★ Performance parameter

Equipment model: XK-B870T  
 Product name: 10 Vibrator Bowls Chain Bucket Packaging Machine  
 Counting method: optical fiber counting/blocking and putting  
 Bag size: width 40-140 length less than 200 (conventional 140)  
 Packing speed: 1-60 bags/min  
 Sealing shape: stripe, back seal/three side seal (usually back seal)  
 Voltage power: 220V/50HZ P≈3.2KW  
 Air supply: 0.4-0.8MPA  
 Bag mouth shape: figure cutter tooth shape  
 Dimensions: length 3850mm/width 1500mm/ height 1550mm  
 Weight: about 500KG

★ Scope of application and functional features

1. The product is suitable for 10 kinds of materials or separate packaging, such as screws, such as screws, nuts, plain washers, spring washers, toys, standard parts, etc.. This product uses chain bucket turns box, vibrator bowl, automatic counting on materials to box, chain bucket will to forming machine automatic packaging materials for the products, also can use artificial into other materials mixed packing equipment free space.
2. It is suitable for "OPP/PP/ lamination film" as sealing material.

# B860Z



## XK-B860Z

1. Vibrator bowl automatic arrangement of materials, automatic counting, automatic filling, automatic packing, sealing function, output count.
2. Adopt intelligent temperature control system, stable temperature control, temperature can be adjusted according to needs.
3. The length of packaging bag is adjustable, the total number of packaging is adjustable, the set number of automatic alarm.
4. After packing, the bag is uniform, neat, beautiful and firm. It can also be equipped with coding machine, check and reweigh, labeling machine, hoist and other expansion equipment.

### ★ Performance parameter

Equipment model: XK-B862Z  
 Product name: Hand Throw Belt Type Packaging Machine  
 Counting method: optical fiber counting/blocking and putting  
 Bag size: width 40-140 length less than 200 (conventional 140)  
 Packing speed: 1-60 bags/min  
 Sealing shape: stripe, back seal/three side seal (usually back seal)  
 Voltage power: 220V/50HZ P≈1.5KW  
 Air supply: 0.4-0.8MPA  
 Bag mouth shape: figure cutter tooth shape  
 Dimensions: length 3200mm/ width 750mm/ height 1650mm  
 Weight: about 700KG

### ★ Scope of application and functional features

1. This product is suitable for a variety of manual putting mixing or separate packaging, such as screws, nuts, plain washers, spring washers, toys, standard parts, etc., this product uses bucket climbing type turns box, artificial material delivery to box, belt type will to forming machine automatic packaging materials for the products, this product uses climbing way reduces the height of trailer, convenient and artificial putting.
2. It is suitable for "OPP/PP/ lamination film" as sealing material.







**XK-B862Z**

1. Vibrator bowl automatic arrangement of materials, automatic counting, automatic filling, automatic packing, sealing function, output count.
2. Adopt intelligent temperature control system, stable temperature control, temperature can be adjusted according to needs.
3. The length of packaging bag is adjustable, the total number of packaging is adjustable, the set number of automatic alarm.
4. After packing, the bag is uniform, neat, beautiful and firm. It can also be equipped with coding machine, check and reweigh, labeling machine, hoist and other expansion equipment.

★ Performance parameter

Equipment model: XK-B862Z  
 Product name: 2 Vibrator Bowls Climbing Type Packaging Machine  
 Counting method: optical fiber counting/blocking and putting  
 Bag size: width 40-140 length less than 200 (conventional 140)  
 Packing speed: 1-60 bags/min  
 Sealing shape: stripe, back seal/three side seal (usually back seal)  
 Voltage power: 220V/50HZ P≈1.5KW  
 Air supply: 0.4-0.8MPA  
 Bag mouth shape: figure cutter tooth shape  
 Dimensions: length 3200mm/ width 2100mm/ height 1650mm  
 Weight: About 700KG

★ Scope of application and functional features

1. This product is applicable to automatic mixing under 2 kinds of material or separate packaging, such as screws, nuts, plain washers, spring washers, toys, standard parts, etc., this product uses chain bucket turns feeding box, vibrator bowl, automatic counting on raw materials to box, the bucket will to molding machine automatic packaging materials for the products, this product uses climbing way reduces the height of trailer, convenient and artificial feeding, It can also use the spare space of the equipment to put other materials into mixed packaging manually.
2. It is suitable for "OPP/ CPP/ lamination film" as sealing material.



**XK-B870Z**

1. Vibrator bowl automatic arrangement of materials, automatic counting, automatic filling, automatic packing, sealing function, output count.
2. Adopt intelligent temperature control system, stable temperature control, temperature can be adjusted according to needs.
3. The length of packaging bag is adjustable, the total number of packaging is adjustable, the set number of automatic alarm.
4. After packing, the bag is uniform, neat, beautiful and firm. It can also be equipped with coding machine, check and reweigh, labeling machine, hoist and other expansion equipment.

★ Performance parameter

Equipment model: XK-B870Z  
 Product name: Multi-vibrator Bowl Climbing Type Packaging Machine  
 Counting method: optical fiber counting/blocking and putting  
 Bag size: width 40-140, length less than 200 (conventional 140)  
 Packing speed: 1-60 bags/min  
 Sealing shape: stripe, back seal/three side seal (usually back seal)  
 Voltage power: 220V/50HZ P≈3KW  
 Air supply: 0.4-0.8MPA  
 Bag mouth shape: figure cutter tooth shape  
 Dimensions: length 4700mm/ width 2100mm/ height 1650mm  
 Weight: about 1000KG

★ Scope of application and functional features

1. This product is suitable for a variety of automatic counting material put in mix or separate packaging, such as screws, nuts, plain washers, spring washers, toys, standard parts, etc.. This product uses a chain bucket climbing type to drive the material box to rotate, artificial material delivery to box, automatically packaging products fill the bucket to molding machine. This product uses climbing way reduces the height of trailers more than 10 vibrator bowls work stations can be added after the bucket, which can continue more specifications of material mixing and automatic packaging, and can also use the spare space for manual putting.
2. It is suitable for "OPP/ CPP/ lamination film" as sealing material.

B870Z (Multi-vibrator Bowl Climbing Type Packaging Machine)



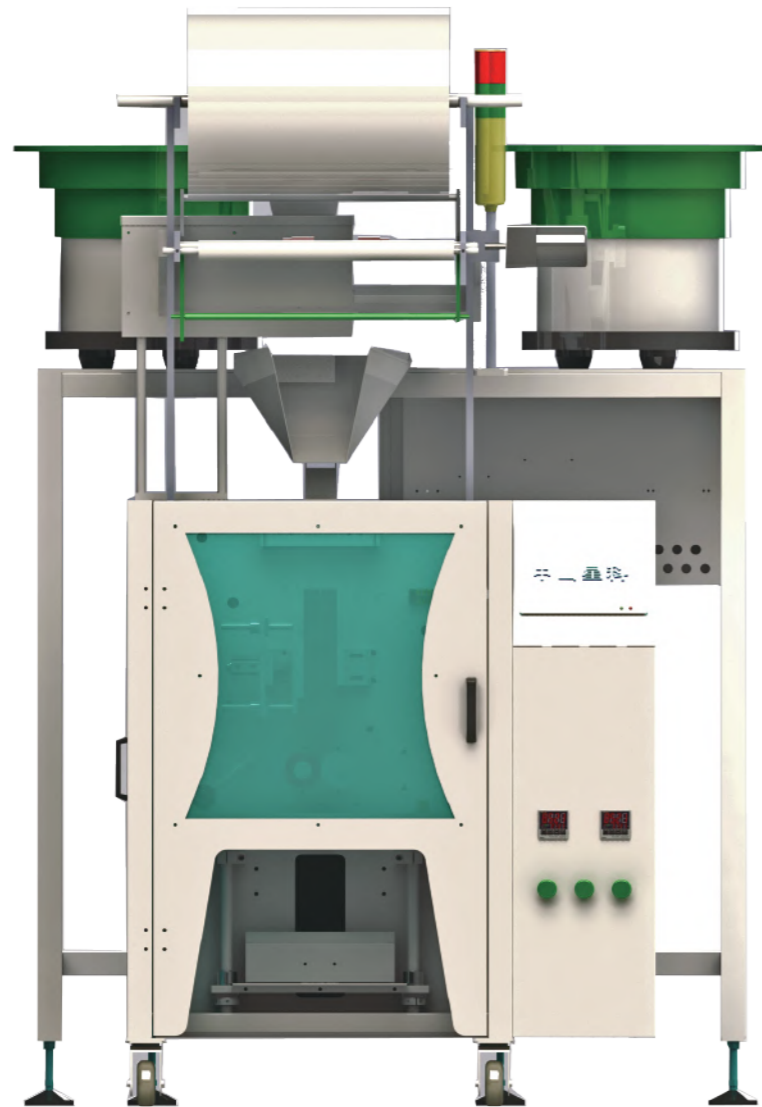

## ★ Technical characteristics

1. The vibrator bowl tailored for the packaging sample can be weighed and packed by weighing method with the accuracy of  $\pm 1g$ .
2. Vibrator bowl automatic arrangement of materials, automatic counting, automatic filling, automatic packing, sealing function, output count.
3. Adopt intelligent temperature control system, stable temperature control, temperature can be adjusted according to needs.
4. The length of packaging bag is adjustable, the total number of packaging is adjustable, and the automatic alarm is given when the set number is reached.
5. After packing, the bag is uniform, neat, beautiful and firm. It can also be equipped with coding machine, check weighing, labeling machine, hoist and other expansion equipment.



**XK-C802**



**XK-C802Z**

## ★ Scope of application and functional

1. This product is suitable for the quantity required more product packaging, all kinds of particles, tablets, hardware items such as packaging, such as screw, nut, number of packages require more, cases of 500pcs or 1000pcs a bag. This product uses weighing complement way measurement, double vibrator bowl, diligence, weighing, first complement way after packaging.
2. It is suitable for "OPP/CPP/ lamination film" as sealing material.

## ★ Performance parameter

Equipment model: XK-C802  
 Product name: Weighing Complement Number Packaging Machine  
 Counting method: weighing complement number  
 Bag size: 40-230 wide and within 300  
 Packing speed: 1-20 bags/min  
 Sealing shape: stripe, back seal/three side seal (usually back seal)  
 Voltage power: 220V/50HZ P $\approx$ 1.5KW  
 Air supply: 0.4-0.8MPA  
 Bag mouth shape: figure cutter tooth shape  
 Dimensions: length 1300mm/ width 1100mm/ height 1800mm  
 Weight: about 400KG

## ★ Performance parameter

Equipment model: XK-C802Z  
 Product name: Weighing Complement Number Packaging Machine + Hoist  
 Counting method: weighing complement number  
 Bag size: 40-230 wide and within 300  
 Packing speed: 1-20 bags/min  
 Sealing shape: stripe, back seal/three side seal (usually back seal)  
 Voltage power: 220V/50HZ P $\approx$ 1.5KW  
 Air supply: 0.4-0.8MPA  
 Bag mouth shape: figure cutter tooth shape  
 Dimensions: length 3500mm/ width 1100mm/ height 2500mm  
 Weight: about 550KG

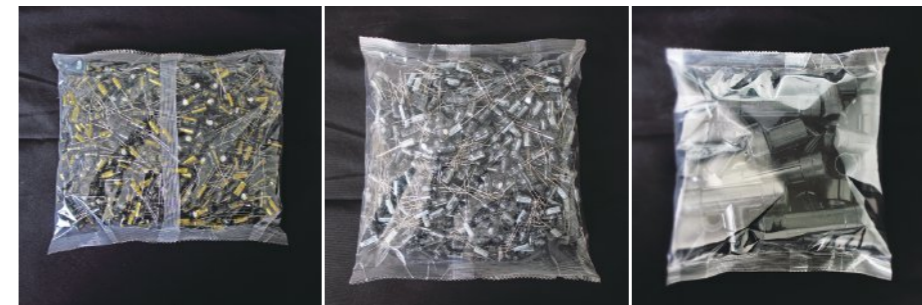

# Non-standing Packaging

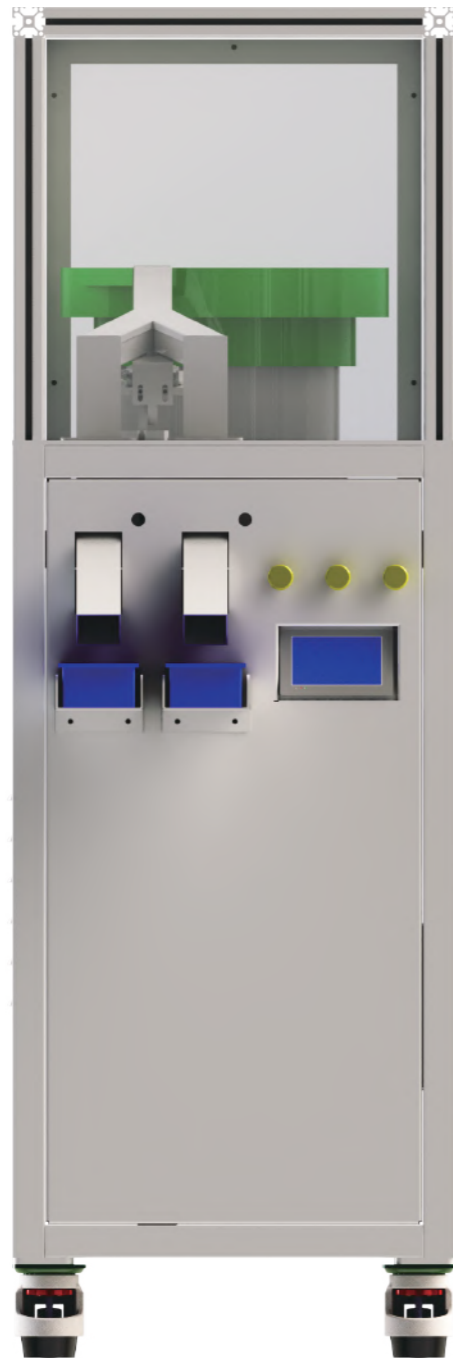

**XK-B860K**

★ **Technical characteristics**

1. Automatic filling, automatic packing, sealing function, output count.
2. Adopt intelligent temperature control system, stable temperature control, temperature can be adjusted according to needs.
3. The universal performance is large, any material can be packaged manually, and the bag length can be adjusted.
4. The length of the bag can be adjusted, the total amount of the package can be adjusted, and the automatic alarm can be reached when the set number of times is reached.
5. A manual putting sensor can be installed to ensure that the packaging is carried out after each putting to avoid empty bags.
6. After packing, the bag is uniform, neat, beautiful and firm. It can also be equipped with coding machine, check weighing, labeling machine, hoist and other expansion equipment.
7. Can punch the bag.

★ **Performance parameter**

Equipment model: XK-B860K  
 Product name: Hanging Empty Packaging Machine  
 Counting method: Hand release/with vibrator bowl  
 Bag size: 40-140 wide, less than 250 in length (conventional 140)  
 Packing speed: 1-60 bags / min  
 Sealing shape: stripe, back seal/three side seal (usually back seal)  
 Voltage power: 220V/50HZ P≈0.6KW  
 Air supply: 0.4-0.8MPA  
 Bag mouth shape: figure cutter tooth shape  
 Dimensions: length 2500mm/ width 700mm/ height 1550mm  
 Weight: about 150KG

★ **Scope of application and functional features**

1. The surface is painted or electroplated. Products with extremely high surface requirements require hanging holes after the bag is formed. For example, toys, electroplated plastic parts, spray paint parts, electronic component switches etc., use manual materials. To prevent the vibrator bowl from scratching the surface of the product.
2. If there is no special requirement on the surface of the product, a vibrator bowl can also be added to increase counting and packaging.
3. It is suitable for "OPP/ CPP/ lamination film" as sealing material.

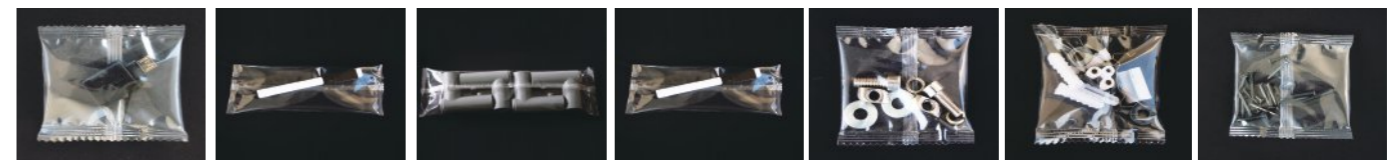

**XK-B860ZS**

★ **Technical characteristics**

1. Automatic filling, automatic packing, sealing function, output count.
2. Adopt intelligent temperature control system, stable temperature control, temperature can be adjusted according to needs.
3. The length of the bag can be adjusted, the total amount of the package can be adjusted, and the automatic alarm can be reached when the set number of times is reached.
4. Cooperate with injection molding machine for injection counting and packaging.
5. After packing, the bag is uniform, neat, beautiful and firm. It can also be equipped with coding machine, check weighing, labeling machine, hoist and other expansion equipment.

★ **Performance parameter**

Equipment model: XK-B860ZS  
 Product name: Injection Packaging Machine  
 Counting method: Cooperate with injection molding equipment  
 Bag size: 40-200 wide, less than 300 in length  
 Packing speed: 1-60 bags / min  
 Sealing shape: stripe, back seal/three side seal (usually back seal)  
 Voltage power: 220V/50HZ P≈1KW  
 Air supply: 0.4-0.8MPA  
 Bag mouth shape: figure cutter tooth shape  
 Dimensions: length 3500mm/ width 700mm/ height 1550mm (With assembly line)  
 Weight: about 250KG

★ **Scope of application and functional features**

1. The surface is painted or electroplated. Products with extremely high surface requirements require hanging holes after the bag is formed. For example, toys, electroplated plastic parts, spray paint parts, electronic component switches etc., use manual materials. To prevent the vibrator bowl from scratching the surface of the product.
2. It is suitable for "OPP/ CPP/ lamination film" as sealing material.



**XK-B860ZX**

★ Technical characteristics

1. Automatic filling, automatic packing, sealing function, output count.
2. Adopt intelligent temperature control system, stable temperature control, temperature can be adjusted according to needs.
3. The length of the bag can be adjusted, the total amount of the package can be adjusted, and the automatic alarm can be reached when the set number of times is reached.
4. The size of the chain box is enlarged, the head of the machine is enlarged, and the body is longer.
5. After packing, the bag is uniform, neat, beautiful and firm. It can also be equipped with coding machine, check weighing, labeling machine, hoist and other expansion equipment.

★ Performance parameter

Equipment model: XK-B860ZX  
 Product name: Climbing Type Enlarged Packaging Machine  
 Counting method: cooperate with injection molding equipment  
 Bag size: 100-230 wide, less than 350 in length  
 Packing speed: 1-40 bags / min  
 Sealing shape: stripe, back seal/three side seal (usually back seal)  
 Voltage power: 220V/50HZ P≈1KW  
 Air supply: 0.4-0.8MPA  
 Bag mouth shape: figure cutter tooth shape  
 Dimensions: length 5000mm/ width 1800mm/ height 2550mm  
 Weight: about 800KG

★ Scope of application and functional features

1. This product is suitable for packaging products that are large or large in quantity, bag-in-bag and other product packaging, such as springs, compression springs, accessory packages, capacitors, screws, spring washers etc., which are large in number. Use manual weighing and counting. Automatic packaging is carried out in the feeding box, and the overall size of the chain bucket and the machine head is increased.
2. It is suitable for "OPP/ CPP/ lamination film" as sealing material.



**XK-B862C**

★ Technical characteristics

1. Automatic filling, automatic packing, sealing function, output count.
2. Adopt intelligent temperature control system, stable temperature control, temperature can be adjusted according to needs.
3. The length of the bag can be adjusted, the total amount of the package can be adjusted, and the automatic alarm can be reached when the set number of times is reached.
4. The size of the chain box is enlarged, the head of the machine is enlarged, and the body is longer.
5. After packing, the bag is uniform, neat, beautiful and firm. It can also be equipped with coding machine, check weighing, labeling machine, hoist and other expansion equipment.

★ Performance parameter

Equipment model: XK-B862C  
 Product name: Climbing Type Enlarged Packaging Machine  
 Counting method: Fiber counting/ blocking and putting  
 Bag size: 40-140 wide, less than 300 in length  
 Packing speed: 1-60 bags / min  
 Sealing shape: stripe, back seal/three side seal (usually back seal)  
 Voltage power: 220V/50HZ P≈2KW  
 Air supply: 0.4-0.8MPA  
 Bag mouth shape: figure cutter tooth shape  
 Dimensions: length 1800mm/width 1300mm/ height 1800mm  
 Weight: about 400KG

★ Scope of application and functional features

1. This product is suitable for mixed packaging of less than two materials or product packaging with a large number of separate products, such as screws, nuts, buttons, terminals, standard parts, etc., the overall body size of this product is increased, increased the length limit of the bag.
2. It is suitable for "OPP/ CPP/ lamination film" as sealing material.



**XK-D801**

★ Performance parameter

Equipment model: XK-D801  
 Product name: Single Station Counting Machine  
 Counting method: Fiber count  
 Counting speed: 0.3-1s/piece  
 Voltage power: 220V/50HZ P≈0.5KW  
 Air supply: 0.4-0.8MPA  
 Prompt method: Alarm prompt according to the set amount  
 Dimensions: length 750mm/ width 450mm/ height 1550mm  
 Weight: about 100KG



★ Performance parameter

Equipment model: XK-D802  
 Product name: Dual-station Counting Machine  
 Counting method: Fiber count  
 Counting speed: 0.3-1s/piece  
 Voltage power: 220V/50HZ P≈0.5KW  
 Air supply: 0.4-0.8MPA  
 Prompt method: Alarm prompt according to the set amount  
 Dimensions: length 750mm/ width 450mm/ height 1550mm  
 Weight: about 100KG

★ Scope of application and functional features

1. This product is suitable for the production line, which needs to be produced according to quantity, or the number of station products that need to be docked according to quantity, for example. When the screws are fixed and hit X screws, can automatically count and prompt through the equipment to place missing or overloaded screws.
2. It is suitable for the counting operation of the production line.

★ Performance parameter

**XK-B866P**

Equipment model: XK-B866P  
 Product name: Belt Type Packaging Machine  
 Counting method: Fiber counting/blocking and putting  
 Bag size: 40-140 wide, less than 200 in length  
 Packing speed: 1-60 bags / min  
 Sealing shape: stripe, back seal/three side seal (usually back seal)  
 Voltage power: 220V/50HZ P≈2KW  
 Air supply: 0.4-0.8MPA  
 Bag mouth shape: figure cutter tooth shape  
 Dimensions: length 3000mm/ width 1700mm/ height 1550mm  
 Weight: about 500KG

★ Technical characteristics

1. Automatic filling, automatic packing, sealing function, output count.
2. Adopt intelligent temperature control system, stable temperature control, temperature can be adjusted according to needs.
3. The length of the bag can be adjusted, the total amount of the package can be adjusted, and the automatic alarm can be reached when the set number of times is reached.
4. After packing, the bag is uniform, neat, beautiful and firm. It can also be equipped with coding machine, check weighing, labeling machine, hoist and other expansion equipment.

★ Scope of application and functional features

1. This product is suitable for products with longer products, more types, multiple materials matched with each other or individually packaged products, such as door latches, long screws, long cylindrical pins, long shape products such as square and long keys, round bars, etc. This product uses belts type instead of chain-bucket putting to avoid jams when long-shaped materials are included in the forming.
2. It is suitable for "OPP/ CPP/ lamination film" as sealing material.

★ Technical characteristics

1. Automatically arrange products and count automatically.
2. Send it to the discharge box according to the set quantity, and prompt the alarm.
3. The number and time of discharge can be set.
4. The total number can be adjusted to reach the set number of automatic alarms.
5. Can be connected to the production line control, with output port.

★ Scope of application and functional features

1. This product is suitable for the production line, which needs to be produced according to quantity, or the number of station products that need to be docked according to quantity, for example. When the screws are fixed and hit X screws, you can automatically count and prompt through the equipment to place missing or overloaded screws.
2. It is suitable for the counting operation of the production line.



**XK-D802**

★ Technical characteristics

1. Automatically arrange products and count automatically.
2. Send it to the discharge box according to the set quantity, and prompt the alarm.
3. The number and time of discharge can be set.
4. The total number can be adjusted to reach the set number of automatic alarms.
5. Can be connected to the production line control, with output port.

# Cylinder Film

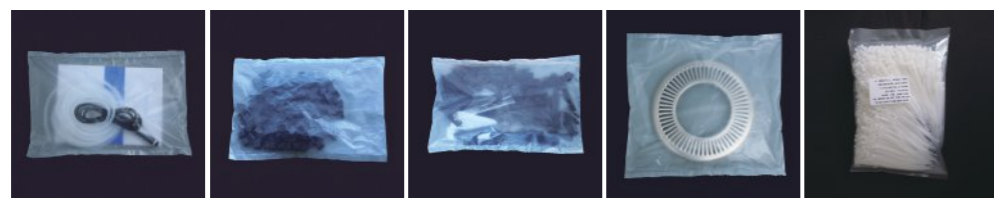

**XK-TM400**

**XK-TM400Z**

★ Scope of application and functional features

1. This product is suitable for products with large quantity and large materials, and requires bagging material PE material, upper and lower sealing cylinder film packaging. Such as rubber particles, injection molded parts, springs, capacitors, plastic standard parts, water pipes, power cords and so on. The bagging size of this product is larger, the opening is larger, and there is no need for forming machine putting, so it can be used for filling and packaging of products with larger size and larger quantity.
2. It is suitable for "PE cylinder film" as sealing material.

★ Performance parameter

Equipment model: XK-TM400  
 Product name: Cylinder Film Packaging Machine  
 Counting method: manual placement / matched with the vibrator bowl  
 Bag size: 100-400 wide, less than 450 in length  
 Packing speed: 5-15 bags / min  
 Sealing : upper and lower cylinder film sealing  
 Voltage power: 220V/50 HZ P ≈ 2.5KW  
 Weight: About 300KG  
 Bag mouth shape: figure cutter tooth shape  
 Dimensions: length 1200 mm/ width 1000mm/ height 950 mm

★ Technical characteristics

1. The bag is made of cylinder film, and there is no need for shaping.
2. Fault self-diagnosis, and alarm.
3. Man-machine interface operation, parameter setting is simple, convenient and fast.
4. Use heating wire temperature control seal, pneumatic suction bag pull bag.
5. The transmission system is simple and clear. The working property is reliable and the maintenance is convenient.
6. The width of the bag can be changed at any time, only need to change the cylinder film.
7. Goods sense to prevent empty bags.

★ Scope of application and functional features

1. This product is suitable for products with large quantity and large materials, and requires bagging material PE material, upper and lower sealing cylinder film packaging. Such as rubber particles, injection molded parts, springs, capacitors, plastic standard parts, water pipes, power cords and so on. The bagging size of this product is larger, the opening is larger, and there is no need for forming machine putting, so it can be used for filling and packaging of products with larger size and larger quantity.
2. It is suitable for "PE cylinder film" as sealing material.

★ Performance parameter

Equipment model: XK-TM400Z  
 Product name: Counting Cylinder Film Packaging Machine  
 Counting method: conveyor belt count / matched with the vibrator bowl  
 Bag size: 100-400 wide, less than 450 in length  
 Packing speed: 5-15 bags / min  
 Sealing : upper and lower cylinder film sealing  
 Voltage power: 220V/50 HZ P ≈ 2.5KW  
 Weight: About 300KG  
 Bag mouth shape: figure cutter tooth shape  
 Dimensions: length 2500 mm/ width 1000mm/ height 950 mm

★ Technical characteristics

1. The bag is made of cylinder film, and there is no need for shaping.
2. Fault self-diagnosis, and alarm.
3. Man-machine interface operation, parameter setting is simple, convenient and fast.
4. Use heating wire temperature control seal, pneumatic suction bag pull bag.
5. The transmission system is simple and clear. The working property is reliable and the maintenance is convenient.
6. The width of the bag can be changed at any time, only need to change the cylinder film.
7. Cooperate with conveyor belt or vibrator bowl to automatically count, fill, automatically pack, seal, and cut.



# Packaging Auxiliary Equipment



## ★ Performance parameter

### XK-B80K

Equipment model: XK-B80K  
 Product name: Fast Check Weighing  
 Sorting mode: belt sorting  
 Maximum weight: less than 500g (customized)  
 Packing speed: 40 bags / min  
 Sorting type: underweight, normal, overweight  
 Voltage power: 220V/50 HZ P ≈ 0.5KW  
 Effective working place: 250\*150MM  
 Dimensions: length 600 mm/ width 300 mm/ height 470 mm  
 Weight: about 20 KG

## ★ Technical characteristics

1. Automatic recognition of product weight, and collect data for multi-stage analysis.
2. Fault self-diagnosis, and alarm.
3. Man-machine interface operation, parameter setting is simple and convenient.
4. The positive and negative rotation of the belt to remove the product, identify the weight of the product OK/NG.
5. The transmission system is simple and clear, reliable working performance, easy maintenance.
6. Separate operation of weighing, sorting and screening belts to speed up efficiency.
7. Article induction, to avoid misjudgment.

## ★ Scope of application and functional features

1. This product is suitable for sorting materials or accessory packages with weight less than 500g, such as accessory packages, drug packaging, food packaging, particle packaging, according to the set weight of the product sorting, qualified and defective products left and right belt movement screening.
2. The material of transmission belt is PU.

### XK-B80S

## ★ Performance parameter

Equipment model: XK-B80S  
 Product name: Check Weighing  
 Sorting mode: belt sorting  
 Maximum weight: less than 500g (customized)  
 Packing speed: 40 bags / min  
 Sorting type: underweight, normal, overweight  
 Voltage power: 220V/50 HZ P ≈ 0.5KW  
 Effective working place: 250\*150MM  
 Dimensions: length 600 mm/width 260 mm/height 470 mm  
 Weight: about 20 KG

## ★ Scope of application and functional features

1. This product is suitable for sorting materials or accessory kits with a weight not more than 500g, such as accessories kits, drug packaging, food packaging, particle packaging, sorting products according to the set weight, and screening the belt movement of qualified and defective products.
2. The transmission belt is made of PU.



## ★ Technical characteristics

1. Automatically identify the weight of the product and collect data for multi-segment analysis.
2. Fault self-diagnosis and alarm prompt.
3. Man-machine interface operation, parameter setting is simple, convenient and quick.
4. Belt reverse to remove the product, identify the weight of the product OK/NG.
5. The transmission system is simple and clear, the work ability is reliable, and the maintenance is convenient.
6. Weighing, distinguishing and screening belt segment operation to speed up the efficiency.
7. Goods sensing to prevent misjudgment.



## ★ Performance parameter

### XK-TS700

Equipment model: XK-TS700  
 Product name: Product Conveyor Belt  
 Lifting method: geared motor + PVC belt  
 Lifting height: within 500-700MM (adjustable)  
 Lifting speed: 40-100 bags/min  
 Voltage power: 220V/50HZ P ≈ 0.2KW  
 Belt width: 270MM  
 Dimensions: length 1350mm/width 300mm/height 700mm  
 Weight: about 30KG

## ★ Scope of application and functional features

Used to lift the packaged product from the sealing position to other storage boxes to prevent the packaging machine from accumulating in the sealing area when the packaging machine is operating for a long time, causing the machine to clamp the material.  
 Motor: Speed-regulating decelerating motor Belt material: PU  
 Length: about 1350mm Height: about 650mm(adjustable)  
 Width: about 300mm Sheet metal: 304 stainless steel  
 Casters: removable casters  
 Remarks: can be customized according to customer requirements

### XK-LC700

## ★ Performance parameter

Equipment model: XK-LC700  
 Lifting method: geared motor + PVC belt/box  
 Voltage power: 220V/50Hz P ≈ 0.5KW  
 Belt width: 400MM  
 Dimensions: length 1500mm/width 800mm/height 1300mm

Product name: Vibrator Bowl Automatic Putting Machine

Lifting height: within 800-1500mm  
 Feeding method: timing/quantitative  
 Weight: about 50KG

## ★ Scope of application and functional features

This product is used to automatically feed and replenish materials after the vibrator bowl is short of material. When the material of the vibrator bowl reaches the state of lack of material, the product will automatically sense and recognize the material to replenish the material into the vibrator bowl quantitatively or regularly, and slow down if the operation time.

Motor: Speed-regulating decelerating motor

Transmission method: belt/box  
 Height: about 1300mm  
 Sheet metal: 304 stainless steel

Length: about 1500mm  
 Width: about 800mm  
 Casters: removable casters

Remarks: can be customized according to customer requirements

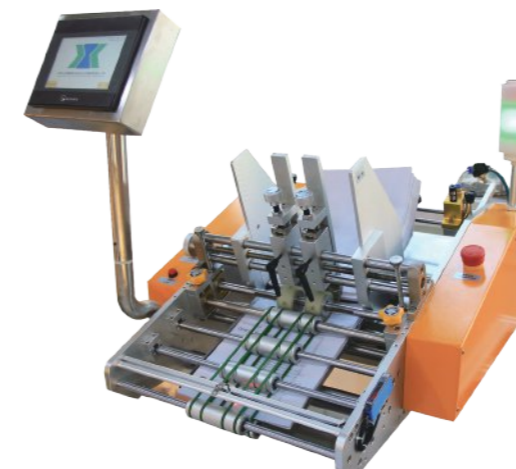

## ★ Scope of application

Sorting of paper items such as instructions, cards, leaflet, ect.

## ★ Performance parameter

### XK-F150

model	XK-F150	XK-F300	XK-F400
thickness	0.06-6	0.06-6	0.06-6
Maximum speed	80 (M/min)	80 (M/min)	60 (M/min)
Minimum card size	30X30 (W*L mm)	100X100 (W*L mm)	100X100 (W*L mm)
Maximum card size	150X150 (W*L mm)	300X300 (W*L mm)	400X400 (W*L mm)
Stack height	Max.500mm	Max.400mm	Max.300mm
Power Specifications	220V/0.4kw	220V /0.4kw	220V/0.4kw

## ★ Technical characteristics

The machine is driven by servo motor, the running speed is stable and fast, and the card issuing speed can reach 500 cards per minute. The imported sensor with strong detection power, fast detection frequency and good stability is used in the detection. Can detect duplicate or missing cards when issuing cards at high speed. The use of large-size touch screen as the machine operation interface, easy to operate. The machine has a powerful error alarm function.



# Pillow Packaging Machine

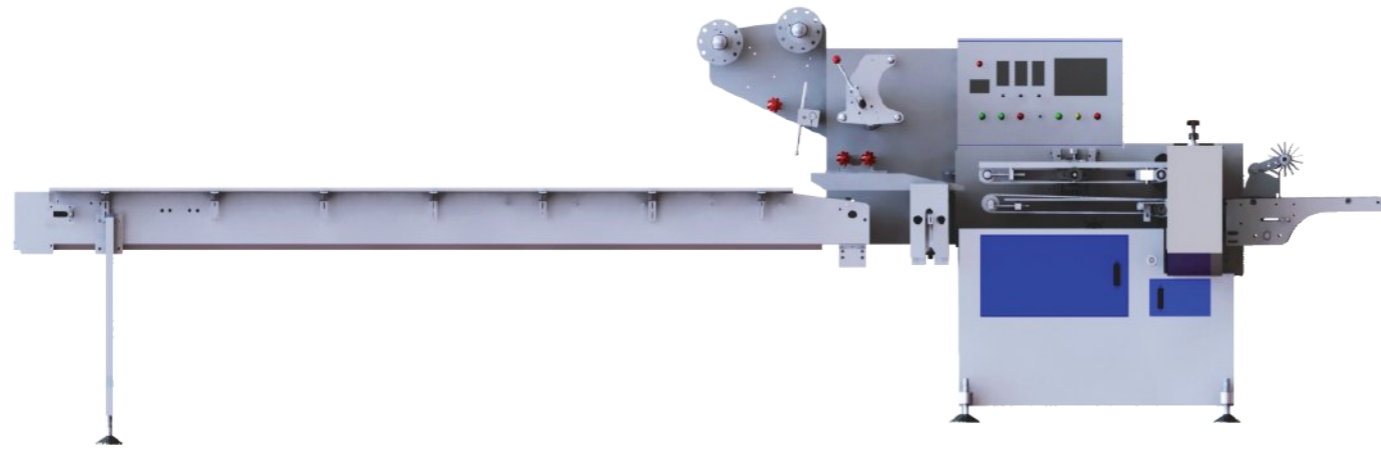

## ★ Technical characteristics

1. Servo control, adjustable bag length, saving time and film.
2. Fault self-diagnosis and alarm.
3. Man-machine interface operation, parameter setting is simple, convenient and quick.
4. Temperature independent control, can be adjusted according to needs, better suitable for all kinds of material packaging.
5. The transmission system is simple and clear, the work ability is reliable, and the maintenance is convenient.
6. High sensitivity photoelectric color code tracking, sealing and cutting more accurate.
7. Goods sensing to prevent empty bags.



## XK-W650S



### ★ Performance parameter

Equipment model: XK-WP650S  
 Product name: Down-walking Paper Belt Pillow Packaging Machine  
 Counting method: manual placement / light eye positioning  
 Bag size: width 50-350, length adjustable  
 Packing speed: 1-100 bags / min  
 Seal form: strip, back seal  
 Voltage power: 220V/50 Hz P ≈ 2.5KW  
 Bag mouth shape: figure cutter tooth shape  
 Dimensions: length 3920 mm/ width 750 mm/height 1350 mm  
 Weight: 600 KG

### ★ Scope of application and functional features

1. It is suitable for packaging various regular objects such as candy, snow cake, egg yolk pie, cake, chocolate, daily necessities, parts, cartons or trays, and requires the product to be upwards, and the process requirements are opposite to the back cover.
2. It is suitable for "OPP/PP/lamination film" as sealing material.

## XK-WP650X

### ★ Performance parameter

Equipment model: XK-WP650X  
 Product name: Down-walking Paper Belt Pillow Packaging Machine  
 Counting method: manual placement / light eye positioning  
 Bag size: width 50-350, length adjustable  
 Packing speed: 1-100 bags / min  
 Seal form: strip, back seal  
 Voltage power: 220V/50 HZ P ≈ 2.5KW  
 Bag mouth shape: figure cutter tooth shape  
 Dimensions: length 3920mm/width 750mm/height 1350 mm  
 Weight: 600 KG

### ★ Scope of application and functional features

1. This product is suitable for all kinds of regular object packaging, such as castors, daily necessities, work piece parts, masks, hotel supplies, disposable tableware, furniture accessories and other cartons or trays.
2. It is suitable for "OPP/PP/lamination film" as sealing material.



## XK-WT650X

### ★ Performance parameter

Equipment model: XK-WT650X  
 Product name: Down-walking Paper Push-board Pillow Type Packaging Machine  
 Counting method: optical fiber counting/blocking and putting  
 Bag size: width 50-350 Adjustable length  
 Packing speed: 1-100 bags/min  
 Sealing shape: stripe, back seal/three side seal (usually back seal)  
 Voltage power: 220V/50Hz P ≈ 2.5KW  
 Bag mouth shape: figure cutter tooth shape  
 Dimensions: length 3920mm/ width 750mm/ height 1350mm

### ★ Scope of application and functional features

1. Suitable for all kinds of regular object packaging, such as castors, instructions, daily necessities, work piece parts, masks, hotel supplies, disposable tableware, furniture accessories and other cartons or trays.
2. It is suitable for "OPP/PP/lamination film" as sealing material.





## Sealing and Cutting

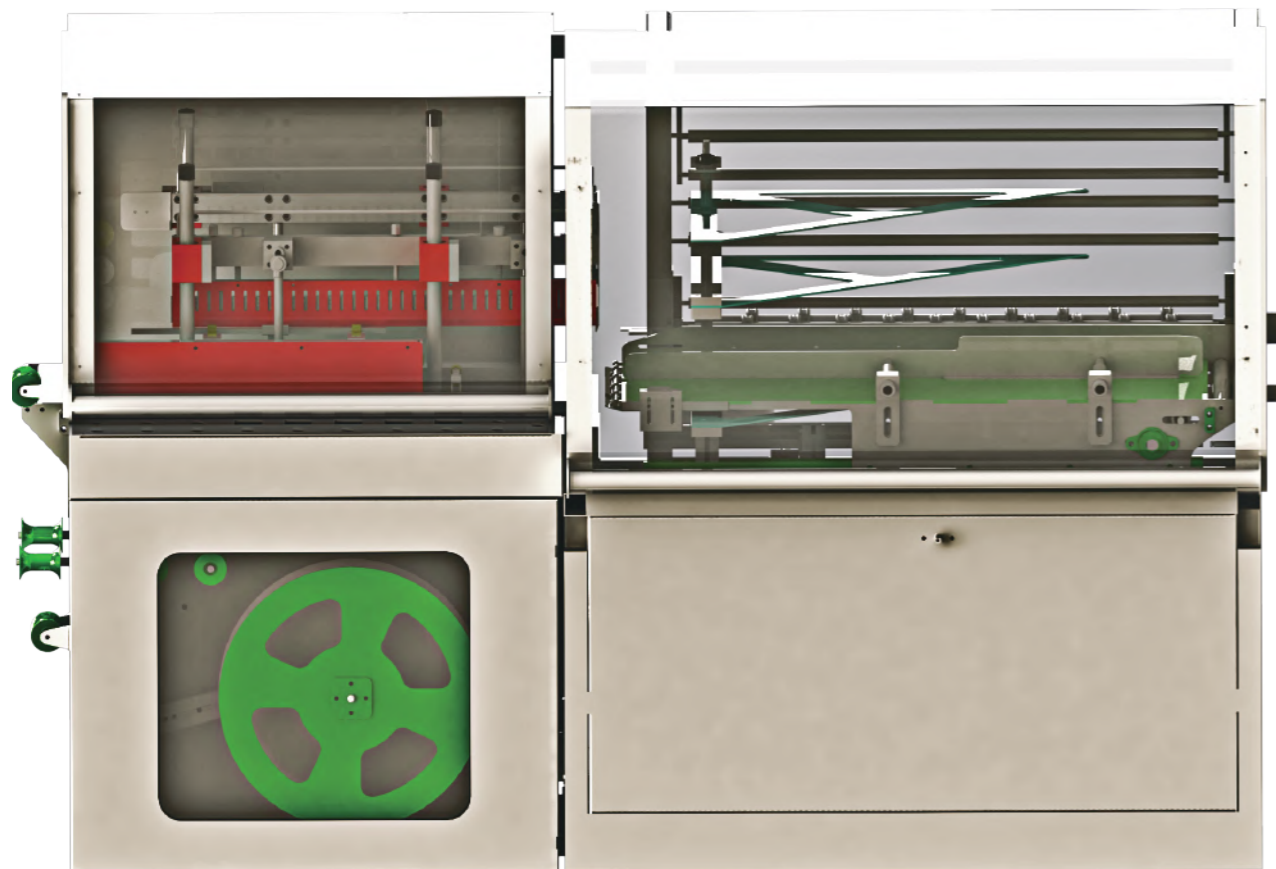

**XK-FL500**



**XK-FQ1000**

### ★ Technical characteristics

1. Fully automatic feeding, conveying, bagging and sealing are completed at one time, with high work efficiency and simple operation. Adjusted the height and width of the handle can change the packaging size.
2. No smoke is produced when sealing, reducing environmental pollution.
3. PCL electric eye control, accurate and durable, and equipped with safety protection device.
4. Material sensing horizontal or vertical double electric eye sensing method.
5. It can be connected to a heat shrinking furnace for shrinking.

### ★ Performance parameter

Equipment model: XK-FL500  
 Product name: Automatic L-type Sealing And Cutting Machine  
 Sensing method: horizontal/vertical  
 Induction method: width within 500, height within 200 (customized)  
 Packing speed: 1-15 bags / min  
 Sealing shape: L-type seal  
 Voltage power: 380V/50Hz P≈12KW  
 Bag mouth shape: flat heat shrink  
 Dimensions: length 6000mm/ width 2500mm/ height 1700mm  
 Weight: about 1000KG

### ★ Scope of application and functional features

1. This product is suitable for food, medicine, chemical, electronic products, printed, toys, furniture, bathroom lighting and other product packaging shrinkage, such as cartons, door panels, glass, hardware frames, suitable for PVC, OPP, POF, PP various heat shrinkable films, the models are mainly conventional products or carton packaging heat shrink.
2. It is suitable for "PVC/OPP/POF/PP/PE".

### ★ Performance parameter

Equipment model: XK-FQ1000  
 Product name: Automatic Upper And Lower Sealing And Cutting Machine  
 Sensing method: horizontal/vertical  
 Induction method: width within 700, height within 300 (customized)  
 Packing speed: 1-15bags / min  
 Sealing shape: upper and lower seal  
 Voltage power: 380V/50Hz P≈3KW  
 Bag mouth shape: flat heat shrink  
 Dimensions: length 2500mm/width 4500mm/ height 1700mm  
 Weight: about 800KG

### ★ Scope of application and functional features

1. This product is suitable for food, medicine, chemical, electronic products, printed, toys, furniture, bathroom lighting and other product packaging shrinkage, such as cartons, door panels, glass, hardware frames, suitable for PVC, OPP, POF, PP various heat shrinkable films, the models are mainly conventional products or carton packaging heat shrink.
2. It is suitable for "PVC/OPP/POF/PP/PE".

★ Performance parameter

XK-FQ1200

Equipment model: XK-FQ2000  
 Product name: Automatic Upper And Lower Sealing And Cutting Machine  
 Sensing method: horizontal/vertical  
 Induction method: width within 900, height within 300 (customized)  
 Packing speed: 5-15bags / min  
 Sealing shape: upper and lower seal  
 Voltage power: 380V/50HZ P≈40KW  
 Bag mouth shape: flat heat shrink  
 Dimensions: length 2500mm/ width 4500mm/ height 1700mm  
 Weight: about 800KG

★ Scope of application and functional features

1. This product is suitable for food, medicine, chemical, electronic products, printed, toys, furniture, bathroom lighting and other product packaging shrinkage, such as cartons, door panels, glass, hardware frames, suitable for PVC, OPP, POF, PP various heat shrinkable films, this model is mainly for shrinking packaging of relatively large objects.  
 2. It is suitable for "PVC/OPP/POF/PP/PE".



XK-R500F

★ Performance parameter

Equipment model: XK-R500F  
 Product name: PE Heat Shrinkable Furnace  
 Sensing method: roller  
 Bag size: customized  
 Voltage power: 380V/50HZ P≈12KW  
 Dimensions: length 2500mm/ width 1500mm/ height 1500mm  
 Weight: about 300KG

★ Scope of application and functional features

1. This product is suitable for food, medicine, chemical, electronic products, printed, toys, furniture, bathroom lighting and other product packaging shrinkage, such as cartons, door panels, glass, hardware frames, suitable for PVC, OPP, POF, PP various heat shrinkable films, this model is mainly for shrinking of PE.  
 2. It is suitable for "PVC/OPP/POF/PP/PE".



★ Performance parameter

XK-R500E

Equipment model: XK-R500E  
 Product name: Heat Shrinkable Furnace  
 Sensing method: roller  
 Bag size: customized  
 Voltage power: 380V/50HZ P≈12KW  
 Dimensions: length 2500mm/ width 1500mm/ height 1500mm  
 Weight: about 300KG

★ Scope of application and functional features

1. This product is suitable for food, medicine, chemical, electronic products, printed, toys, furniture, bathroom lighting and other product packaging shrinkage, such as cartons, door panels, glass, hardware frames, suitable for PVC, OPP, POF, PP various heat shrinkable films, this model is mainly for shrinking of regular POF.  
 2. It is suitable for "PVC/OPP/POF/PP/PE".



Platform Machine

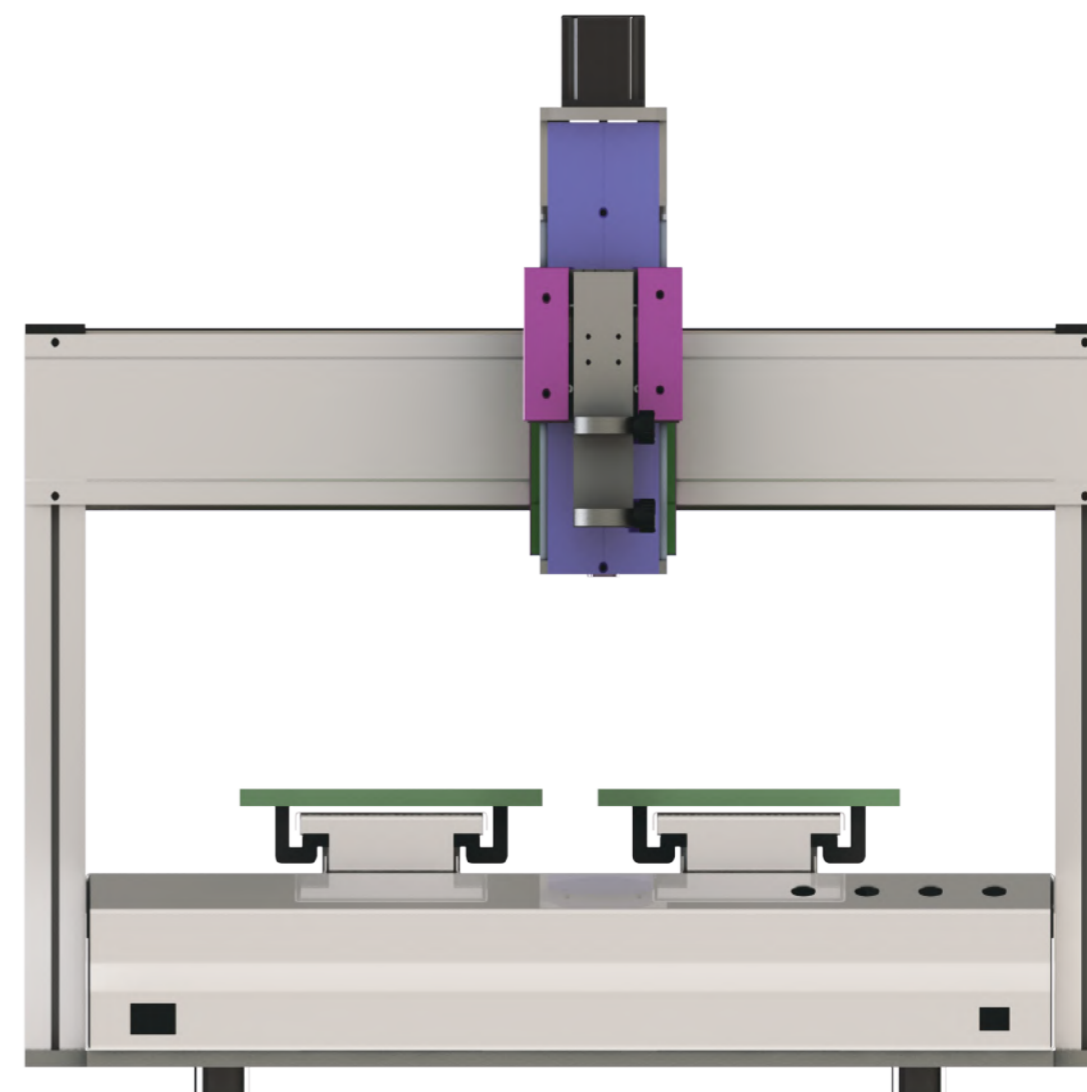



**XK-D531**

★ Scope of application and functional features

1. Semiconductor packaging, PCB board components firmware and protection, LCD glass machine packaging multiple stickers, mobile phone board dispensing, keys, product dispensing, speaker packaging and dispensing, battery box dispensing, auto spare parts painting, hardware accessories packaging painting, quantitative liquid filling, chip bonding and so on.
2. UV, silica, AB, Epoxy(black glue) , White glue, EMI Conductive Glue, silica Gel, Epoxy Gel Resin, Quick Gel, Silver Gel, Red Gel, Tin paste, Heat dissipation paste, Solder paste, transparent Lacquer, Screw Gel.

★ Performance parameter

Equipment model: XK-D531  
 Product name: Single Station Automatic Glue Dispensing Machine  
 Stations: single station  
 Working format: 300 MM\*300MM  
 Running speed: 0-1000 MM/S  
 Repetition accuracy: ±0.02MM  
 Voltage power: 220V/50 HZ P≈0.7KW  
 Air supply: 0.4~0.8MPA  
 Dimensions: length 600mm/width 600mm/height 650mm  
 Weight: 80 KG

★ Technical characteristics

1. With drawing points, lines, arcs, circles and other irregular dispensing distance, irregular curve continuous tween input program and three dimensional dispensing function.
2. Continuous dispensing function of irregular curves such as arbitrary points, lines, surfaces, arcs, etc.
3. The glue quantity is controlled evenly, can be interpolated before and after processing, and has its own vacuum glue absorption function to avoid the problems of uneven glue quantity, wire drawing, rough edge and so on.
4. The automatic compensation function of dispensing strength makes the operation more convenient.
5. XY area array, translation and rotation operation function, reversing board, suitable for different stations, dual-station switching operation.
6. The fixture can be customized according to the characteristics of the product and has a wide range of application.
7. The program corresponding to the product can be stored without secondary editing.
8. If the product needs rotary processing, the interpolation shaft can be installed for processing.

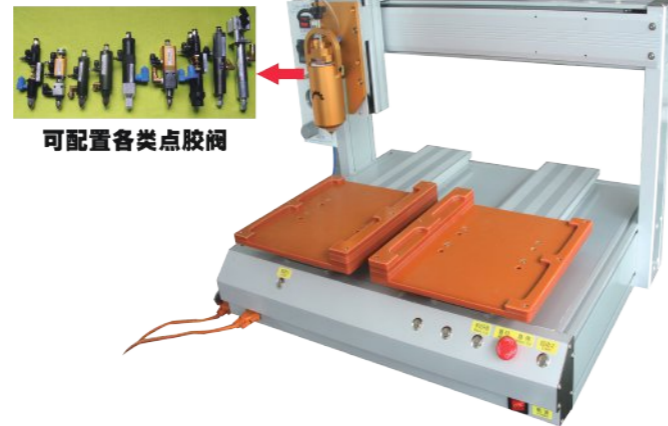

**XK-D531-2Y**

★ Scope of application and functional features

1. Semiconductor packaging, PCB board components firmware and protection, LCD glass machine packaging multiple stickers, mobile phone board dispensing, keys, product dispensing, speaker packaging and dispensing, battery box dispensing, auto spare parts painting, hardware accessories packaging painting, quantitative liquid filling, chip bonding and so on.
2. UV, silica, AB, Epoxy(black glue) , White glue, EMI Conductive Glue, silica Gel, Epoxy Gel Resin, Quick Gel, Silver Gel, Red Gel, Tin paste, Heat dissipation paste, Solder paste, transparent Lacquer, Screw Gel.

★ Performance parameter

Equipment model: XK-D531-2Y  
 Product name: Dual-station Platform Glue Dispensing Machine  
 Stations: dual-stations  
 Working format: 300\*300MM  
 Running speed: 0-1000MM/S  
 Repetition accuracy: ±0.02MM  
 Voltage power: 220V/50 HZ P≈0.7KW  
 Air supply: 0.4-0.8MPA  
 Dimensions: length 750mm/width 600mm/height 650mm  
 Weight: 80 KG

★ Technical characteristics

1. With drawing points, lines, arcs, circles and other irregular dispensing distance, irregular curve continuous tween input program and three dimensional dispensing function.
2. Continuous dispensing function of irregular curves such as arbitrary points, lines, surfaces, arcs, etc.
3. The glue quantity is controlled evenly, can be interpolated before and after processing, and has its own vacuum glue absorption function to avoid the problems of uneven glue quantity, wire drawing, rough edge and so on.
4. The automatic compensation function of dispensing strength makes the operation more convenient.
5. XY area array, translation and rotation operation function, reversing board, suitable for different stations, dual-station switching operation.
6. The fixture can be customized according to the characteristics of the product and has a wide range of application.
7. The program corresponding to the product can be stored without secondary editing.
8. If the product needs rotary processing, the interpolation shaft can be installed for processing.

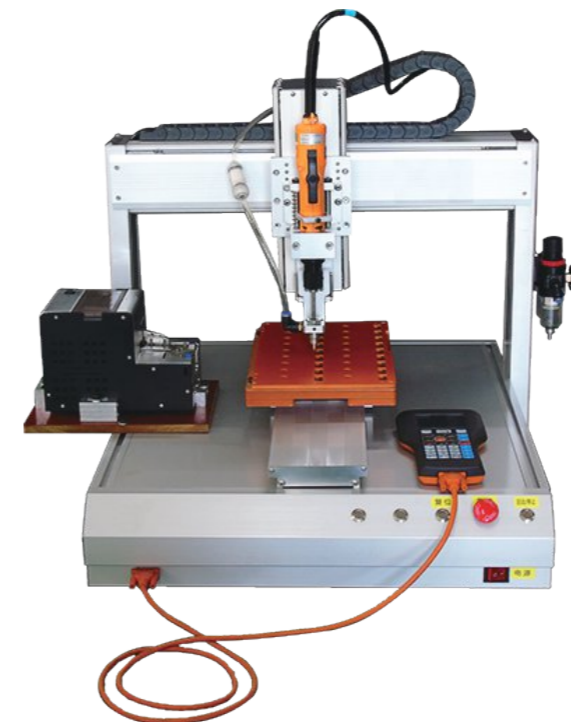

**XK-L531**

★ Scope of application and functional features

1. Hardware industry, electronics industry, lighting industry, standard parts industry, auto parts.
2. Suitable for all kinds of stainless steel, galvanized, iron, copper, plastic and other screws.
3. It is suitable for head cross, one-word, inner hexagon, plum blossom, inner triangle, H head and so on.
4. Screw size range: M1-M5, the length is ≤ 19.

★ Performance parameter

Equipment model: XK-L531  
 Product name: Single Station Platform Lock Screw Machine  
 Stations: single station  
 Working format: 300 MM\*300MM  
 Running speed: 0-1000 MM/S  
 Repetition accuracy: ±0.02MM  
 Voltage power: 220V/50 HZ P≈0.7KW  
 Air supply: 0.4~0.8MPA  
 Dimensions: length 600mm/width 600mm/height 650mm  
 Weight: 80 KG  
 Applicable screw head:

★ Technical characteristics

1. Replace the traditional manual tightening of screws, the screws are automatically arranged, feeding, automatic locking, and counting.
2. It is suitable for a variety of screw locks, and the torque of the electric screwdriver can be adjusted as required to ensure the quality of the locks, fast and stable.
3. Support cycle processing, single processing, automatic processing, single-step processing, etc. The processing graphics can display the shape of the graphics in the processing file very intuitively.
4. With intelligent detection function, it can detect leaked locks, floating locks, sliding—filament, and give an alarm.
5. The equipment is small and exquisite, low noise, easy to put in the production line.



**XK-L531-2Y**

★ Scope of application and functional features

1. Hardware industry, electronics industry, lighting industry, standard parts industry, auto parts.
2. Suitable for all kinds of stainless steel, galvanized, iron, copper, plastic and other screws.
3. It is suitable for head cross, one-word, inner hexagon, plum blossom, inner triangle, H head and so on.
4. Screw size range: M1-M5, the length is ≤ 19.

★ Performance parameter

Equipment model: XK-L531-2Y  
 Product name: Double Station Platform Lock Screw Machine  
 Stations: double station  
 Working format: 300 MM\*300MM  
 Running speed: 0-1000 MM/S  
 Repetition accuracy: ±0.02MM  
 Voltage power: 220V/50 HZ P≈0.7KW  
 Air supply: 0.4~0.8MPA  
 Dimensions: length 750mm/width 600mm/height 650 mm  
 Weight: 80 KG  
 Applicable screw head:

★ Technical characteristics

1. Replace the traditional manual tightening of screws, the screws are automatically arranged, feeding, automatic locking, and counting.
2. It is suitable for a variety of screw locks, and the torque of the electric screwdriver can be adjusted as required to ensure the quality of the locks, fast and stable.
3. Support cycle processing, single processing, automatic processing, single-step processing, etc. The processing graphics can display the shape of the graphics in the processing file very intuitively.
4. With intelligent detection function, it can detect leaked locks, floating locks, sliding—filament, and give an alarm.
5. The equipment is small and exquisite, low noise, easy to put in the production line.



Various dispensing valves can be configured

可配置各类点胶阀



XK-D1251



Various dispensing valves can be configured

可配置各类点胶阀



XK-LD531-2Y

★ Scope of application and functional features

1. Semiconductor packaging, PCB board components firmware and protection, LCD glass machine packaging multiple stickers, mobile phone board dispensing, keys, product dispensing, speaker packaging and dispensing, battery box dispensing, auto spare parts painting, hardware accessories packaging painting, quantitative liquid filling, chip bonding and so on.
2. UV, silica, AB, Epoxy(black glue) , White glue, EMI Conductive Glue, silica Gel, Epoxy Gel Resin, Quick Gel, Silver Gel, Red Gel, Tin paste, Heat dissipation paste, Solder paste, transparent Lacquer, Screw Gel.

★ Performance parameter

Equipment model: XK-L531  
 Product name: Single Station Platform Lock Screw Machine  
 Stations: single station  
 Working format: 1000 MM\*500MM  
 Running speed: 0-1000 MM/S  
 Repetition accuracy: ±0.02MM  
 Voltage power: 220V/50 HZ P≈0.7KW  
 Air supply: 0.4~0.8MPA  
 Dimensions: length 1600mm/width 900 mm/height 1520 mm  
 Weight: 150 KG

★ Technical characteristics

1. With drawing points, lines, arcs, circles and other irregular dispensing distance, irregular curve continuous tween input program and three-dimensional dispensing function.
2. Continuous dispensing function of irregular curves such as arbitrary points, lines, surfaces, arcs, etc.
3. The glue quantity is controlled evenly, can be interpolated before and after processing, and has its own vacuum glue absorption function to avoid the problems of uneven glue quantity, wire drawing, rough edge and so on.
4. The automatic compensation function of dispensing strength makes the operation more convenient.
5. XY area array, translation and rotation operation function, reversing board, suitable for different stations, dual-station switching operation.
6. The fixture can be customized according to the characteristics of the product and has a wide range of application.
7. The program corresponding to the product can be stored without secondary editing.
8. If the product needs rotary processing, the interpolation shaft can be installed for processing.

★ Scope of application and functional features

1. Semiconductor packaging, PCB board components firmware and protection, LCD glass machine packaging multiple stickers, mobile phone board dispensing, keys, product dispensing, speaker packaging and dispensing, battery box dispensing, auto spare parts painting, hardware accessories packaging painting, quantitative liquid filling, chip bonding and so on.
2. UV, silica, AB, Epoxy(black glue) , White glue, EMI Conductive Glue, silica Gel, Epoxy Gel Resin, Quick Gel, Silver Gel, Red Gel, Tin paste, Heat dissipation paste, Solder paste, transparent Lacquer, Screw Gel.

★ Performance parameter

Equipment model: XK-L531-2Y  
 Product name: Double Station Platform Lock Screw Machine  
 Stations: double station  
 Working format: 300 MM\*300MM  
 Running speed: 0-1000 MM/S  
 Repetition accuracy: ±0.02MM  
 Voltage power: 220V/50 HZ P≈0.7KW  
 Air supply: 0.4~0.8MPA  
 Dimensions: length 1600 mm/width 1200 mm/height 800 mm  
 Weight: 200 KG

★ Technical characteristics

1. With drawing points, lines, arcs, circles and other irregular dispensing distance, irregular curve continuous tween input program and three-dimensional dispensing function.
2. Continuous dispensing function of irregular curves such as arbitrary points, lines, surfaces, arcs, etc.
3. The glue quantity is controlled evenly, can be interpolated before and after processing, and has its own vacuum glue absorption function to avoid the problems of uneven glue quantity, wire drawing, rough edge and so on.
4. The automatic compensation function of dispensing strength makes the operation more convenient.
5. XY area array, translation and rotation operation function, reversing board, suitable for different stations, dual-station switching operation.
6. The fixture can be customized according to the characteristics of the product and has a wide range of application.
7. The program corresponding to the product can be stored without secondary editing.
8. If the product needs rotary processing, the interpolation shaft can be installed for processing.

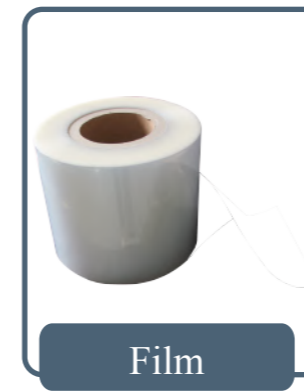

Film



Customized Film



Heating pipe

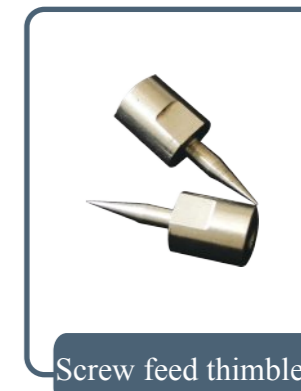

Screw feed thimble



Conveyor

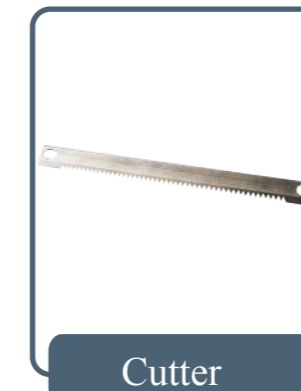

Cutter

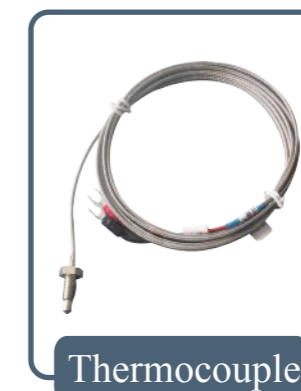

Thermocouple

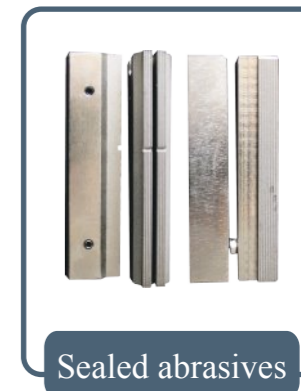

Sealed abrasives